

TM Integral Stacked TAURUS On-board Bass pre-amp



User friendly installation
Customizable Modular design
Optional modules PUNCH, MIDDLE and PRESENCE/BOOST
Unrestricted sequence of connected modules
Low battery indicator
9 or 18V supply

Current supply consumption:
2,7mA @ 9V main configuration / 3,1mA @ 9V maximum configuration

OPTIONS:

ACTIVE / PASSIVE
VOLUME, BLEND, TREBLE, BASS, MIDDLE, PASSIVE TONE , PUNCH

MLO-system **Middle-range Level Optimization**

MLO-system equalization control is conceived to achieve easy and intuitive tailored sound using only bass and treble knobs. This sound correction simplifies finding the proper tone colour. Tone setting characteristics are designed to meet the parameters of the instruments, both technically and musically.

In regular EQ, practically 50% of the bass and treble correction range is used. Adding more low frequencies will result in loss of sound control. Automatic paired mid-range equalization control offers two point correction and optimal middle range frequency tone adjustment, especially in adjacent mid and low spans.

The MLO- equalizer maintains volume level while low frequencies are added to the original sound, changing only the tone, not its volume. (No need for volume correction level).

The musician can simply focus on sound control without knob confusion.

Installation Tips

The pre-amp TM Integral contains three main modules VOLUME, BLEND, BASS /TREBLE with dual push-pull potentiometer. Two optional modules: Passive TONE/MIDDLE and PUNCH can be use in any possible configuration or not at all.

The modules (Pre-amp and optional) are designed to be easily joined together by the flat connecting wire (No soldering required). The sequence of connected modules is unrestricted.

The Taurus pre-amps can be powered either by one or two 9V batteries. The two battery option (18V) is recommended for greatest dynamic range.

On board pre-amps could work on low battery power (3-4V) but would compromise sound quality by its loss of dynamic and consequently, distortion. To prevent this, Taurus pre-amps are built with a Low Battery LED Power Indicator, signaling replacement time.

Taurus recommends installing the LED indicator on the back cover plate of the instrument, eliminating the need for additional connections and adapters. Simply secure the LED (3mm diameter) in the designated opening of the back cover.

TM-Integral INSTALLATION DIAGRAM

Amplification
Taurus

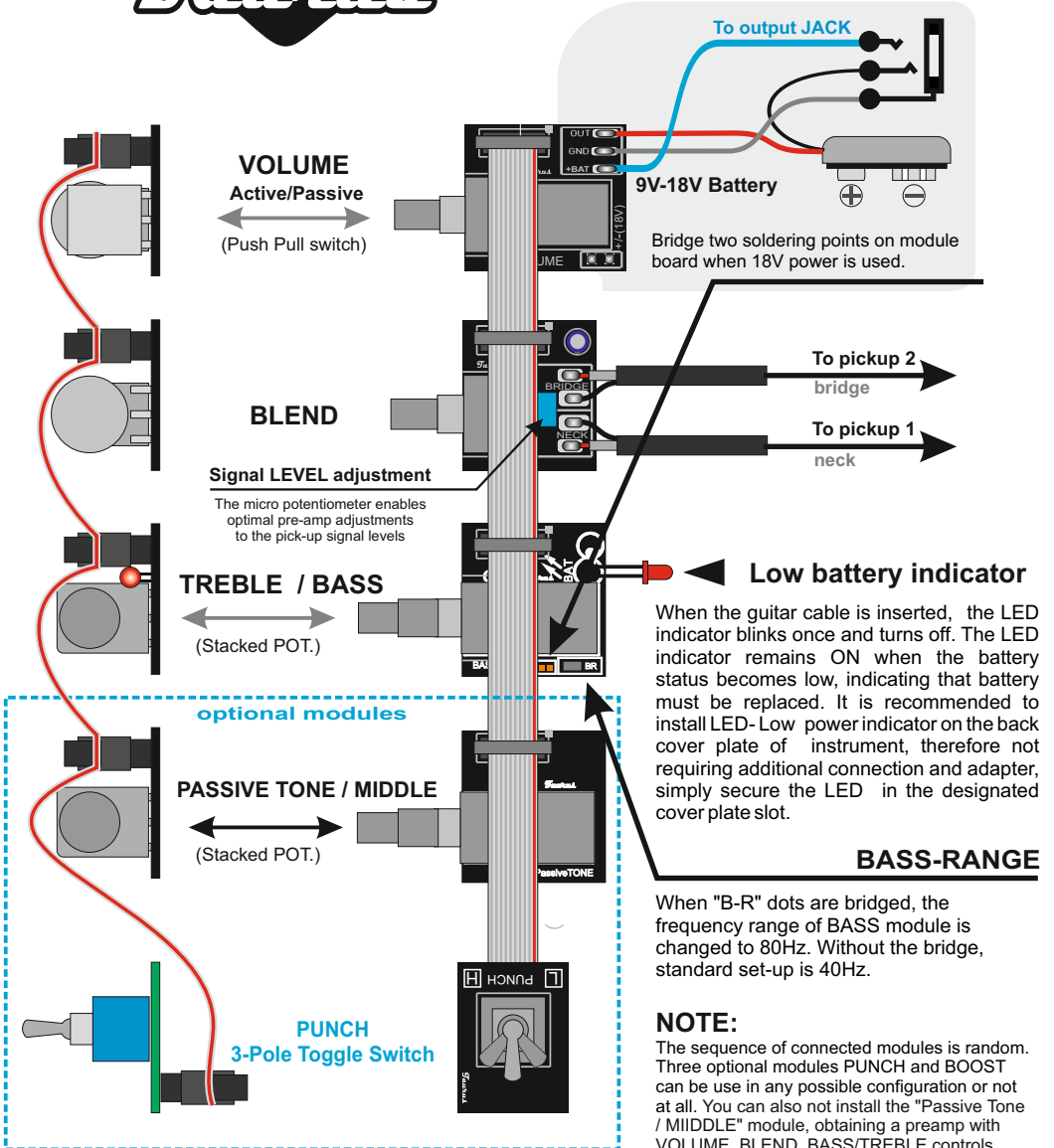

DIMENSIONS

