

A mplification **Taurus**

FEATURES:

- User friendly installation
- Customizable Modular design
- Unrestricted sequence of connected modules
- Low battery indicator
- 9 or 18V supply

PREAMP FUNCTIONS:

- VOLUME control
- Pickups BLEND control
- BASS / TREBLE with MLO system
- PRESENCE/DBS-BOOST with triple micro-switch
- PUNCH tone with triple micro-switch
- ACTIVE/PASSIVE mode switch
- MIDDLE control

Current supply consumption:

2,7mA @ 9V main configuration / 3,1mA @ 9V maximum configuration

MLO-system Middle-range Level Optimization

MLO-system equalization control is conceived to achieve easy and intuitive tailored sound using only bass and treble knobs. This sound correction simplifies finding the proper tone colour. Tone setting characteristics are designed to meet the parameters of the instruments, both technically and musically.

In regular EQ practically 50% of the bass and treble correction range is used. Adding more low frequencies will result in loss of sound control. Automatic paired mid-range equalization control offers two point correction and optimal middle range frequency tone adjustment, especially in adjacent mid and low spans.

The MLO- equalizer maintains volume level while low frequencies are added to the original sound, changing only the tone, not its volume. (No need for volume correction level).

The musician can simply focus on sound control without knob confusion.

TM-2 & TM-1 Installation Tips

Two bass pre-amp models are available. The TM-2 used for two pick-up basses and the TM-1 used for basses with one pick-up only. The pre-amps are identical except for the input modules.

The pre-amp contains four main modules (VOLUME, BLEND, BASS and TREBLE) which must be used. The sequence of connected modules is unrestricted. Three optional modules (PUNCH, PRESENCE/BOOST and MIDDLE) can be use in any possible configuration or not at all. The modules (Pre-amp and optional) are designed to be easily joined together by the flat connecting wire (No soldering required).

The Taurus pre-amps can be powered either by one or two 9V batteries. The two battery option (18V) is recommended for greatest dynamic range.

On board pre-amps could work on low battery power (3-4V) but would compromise sound quality by its loss of dynamic and consequently, distortion. To prevent this, Taurus pre-amps are built with a Low Battery LED Power Indicator, signaling replacement time.

Taurus recommends installing the LED indicator on the back cover plate of the instrument, eliminating the need for additional connections and adapters. Simply secure the LED (3mm diameter) in the designated opening of the back cover.

Main modules

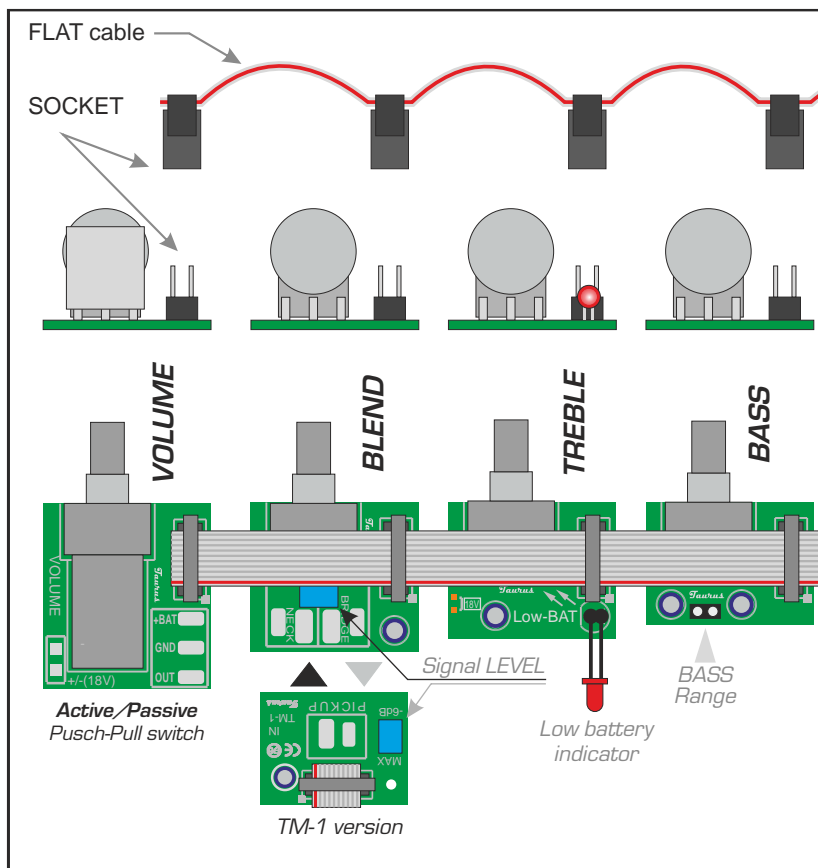

Optional modules

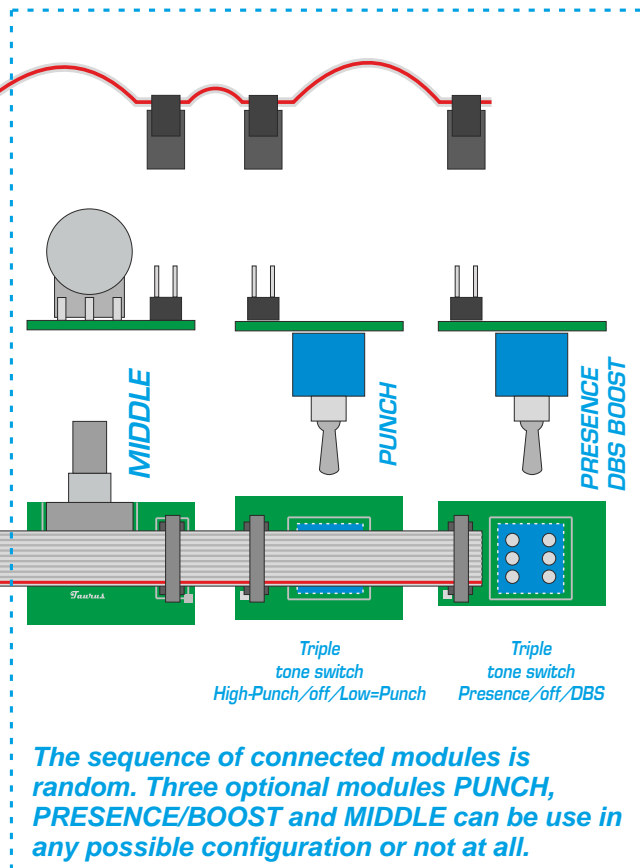

The sequence of connected modules is random. Three optional modules PUNCH, PRESENCE/BOOST and MIDDLE can be use in any possible configuration or not at all.

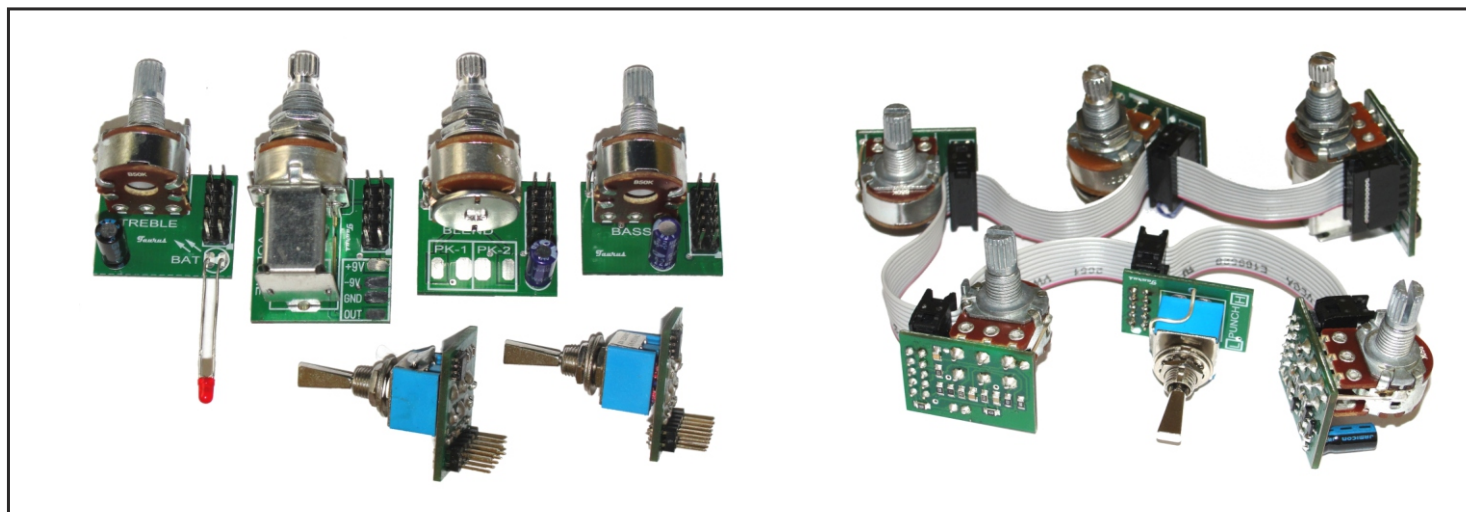

TM-2 / 9V INSTALLATION DIAGRAM

Amplication Taurus

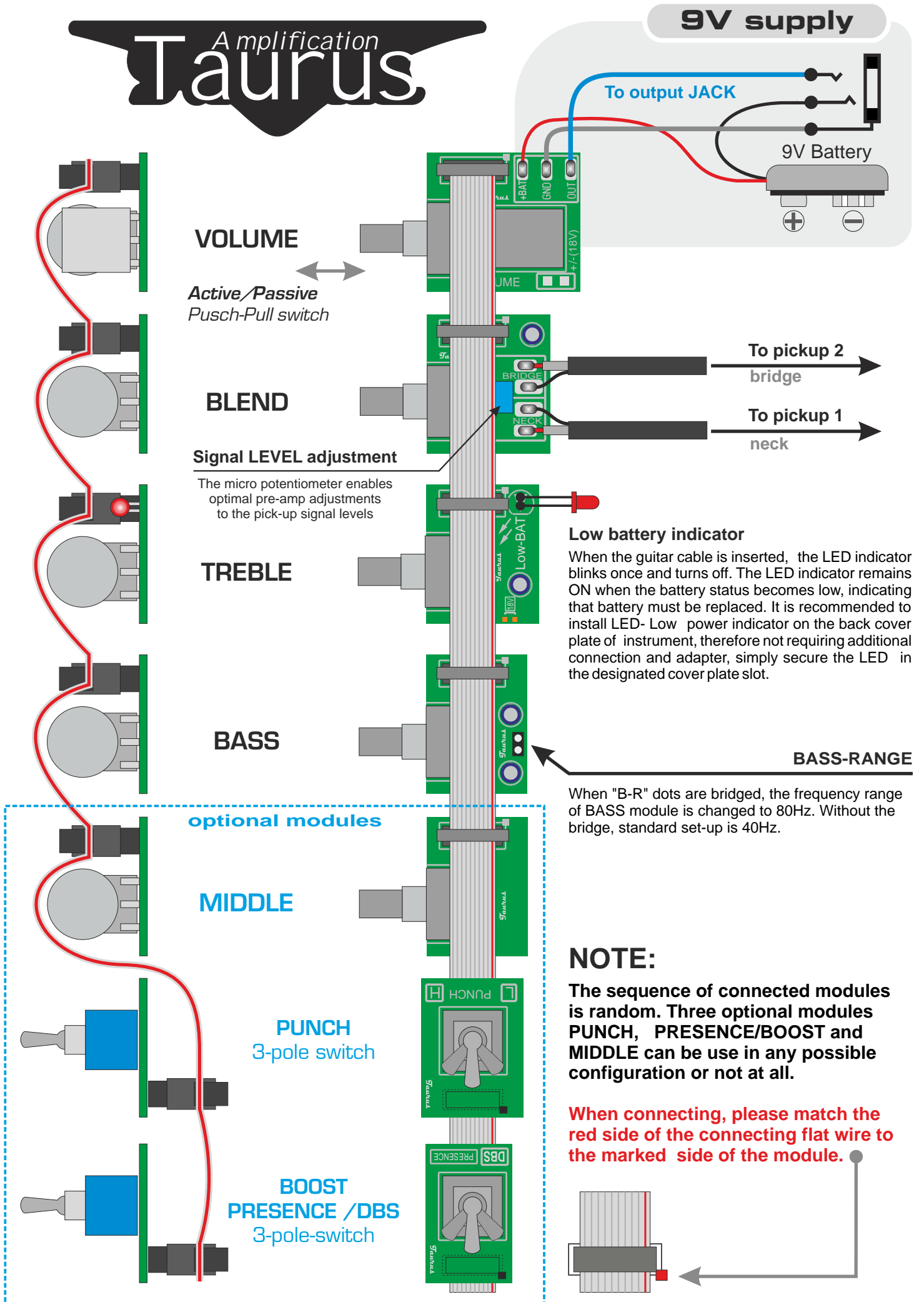

TM-2 / 18V INSTALLATION DIAGRAM

Amplication Taurus

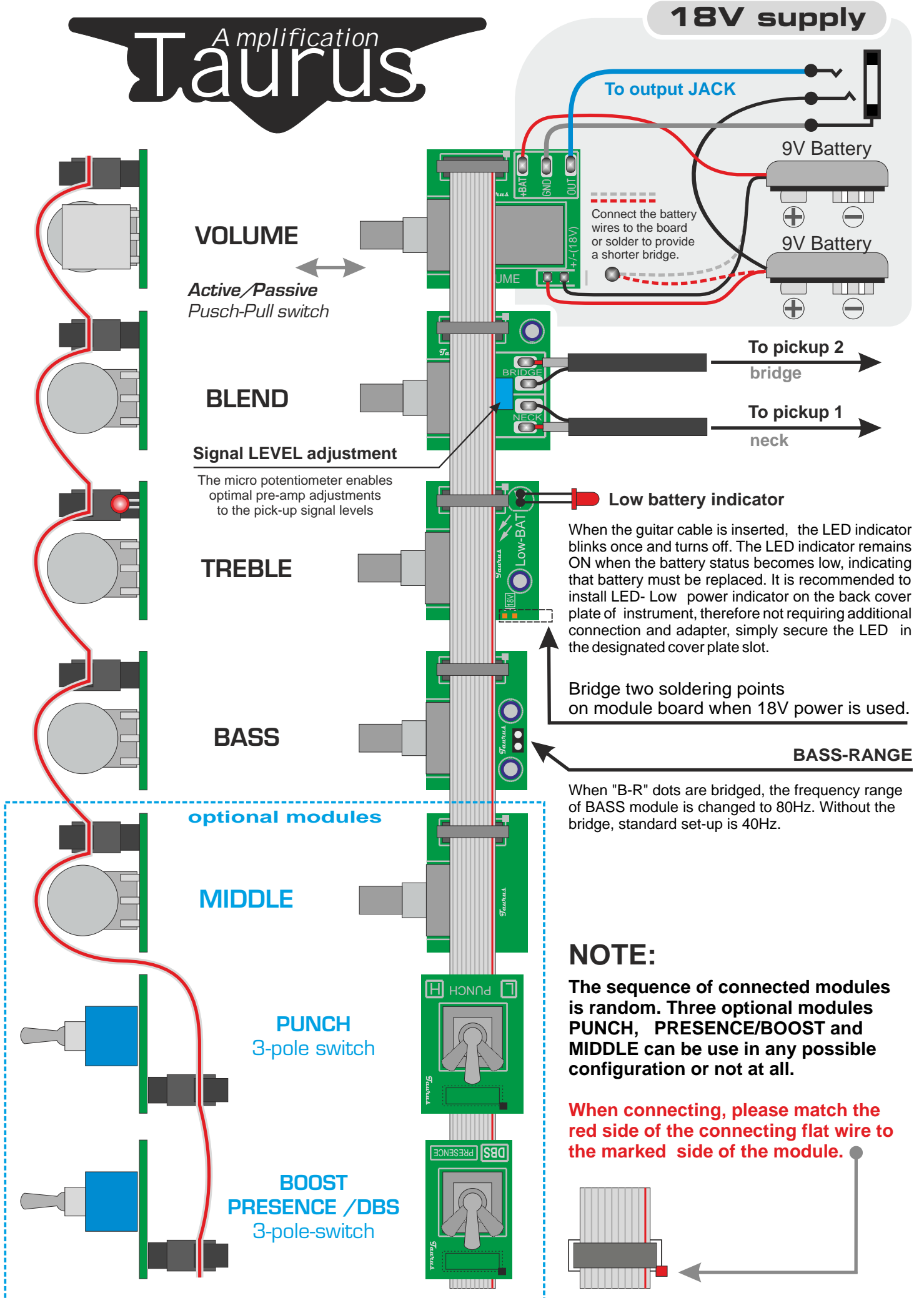

18V supply

VOLUME

Active/Passive
Push-Pull switch

BLEND

Signal LEVEL adjustment
The micro potentiometer enables optimal pre-amp adjustments to the pick-up signal levels

TREBLE

BASS

optional modules

MIDDLE

PUNCH
3-pole switch

BOOST
PRESENCE /DBS
3-pole-switch

To output JACK

9V Battery

9V Battery

Connect the battery wires to the board or solder to provide a shorter bridge.

To pickup 2
bridge

To pickup 1
neck

Low battery indicator

When the guitar cable is inserted, the LED indicator blinks once and turns off. The LED indicator remains ON when the battery status becomes low, indicating that battery must be replaced. It is recommended to install LED- Low power indicator on the back cover plate of instrument, therefore not requiring additional connection and adapter, simply secure the LED in the designated cover plate slot.

Bridge two soldering points on module board when 18V power is used.

BASS-RANGE

When "B-R" dots are bridged, the frequency range of BASS module is changed to 80Hz. Without the bridge, standard set-up is 40Hz.

NOTE:

The sequence of connected modules is random. Three optional modules PUNCH, PRESENCE/BOOST and MIDDLE can be use in any possible configuration or not at all.

When connecting, please match the red side of the connecting flat wire to the marked side of the module.

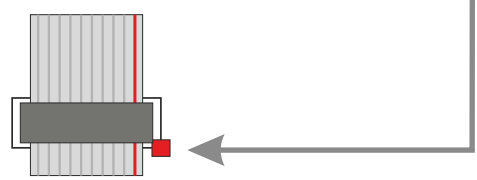

TM-1 / 9V INSTALLATION DIAGRAM

Amplication
Taurus

9V supply

To output JACK

9V Battery

VOLUME

Active/Passive
Push-Pull switch

Signal LEVEL
adjustment
To pickup

TREBLE

BASS

optional modules

MIDDLE

PUNCH
3-pole switch

BOOST
PRESENCE /DBS
3-pole-switch

To pickup

Low battery indicator

When the guitar cable is inserted, the LED indicator blinks once and turns off. The LED indicator remains ON when the battery status becomes low, indicating that battery must be replaced. It is recommended to install LED- Low power indicator on the back cover plate of instrument, therefore not requiring additional connection and adapter, simply secure the LED in the designated cover plate slot.

BASS-RANGE

When "B-R" dots are bridged, the frequency range of BASS module is changed to 80Hz. Without the bridge, standard set-up is 40Hz.

NOTE:

The sequence of connected modules is random. Three optional modules PUNCH, PRESENCE/BOOST and MIDDLE can be use in any possible configuration or not at all.

When connecting, please match the red side of the connecting flat wire to the marked side of the module.

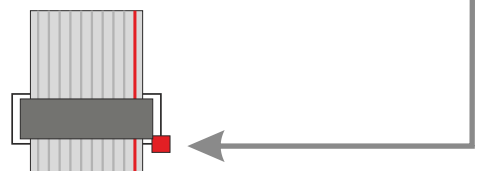

TM-1 / 18V INSTALLATION DIAGRAM

Amplication
Taurus

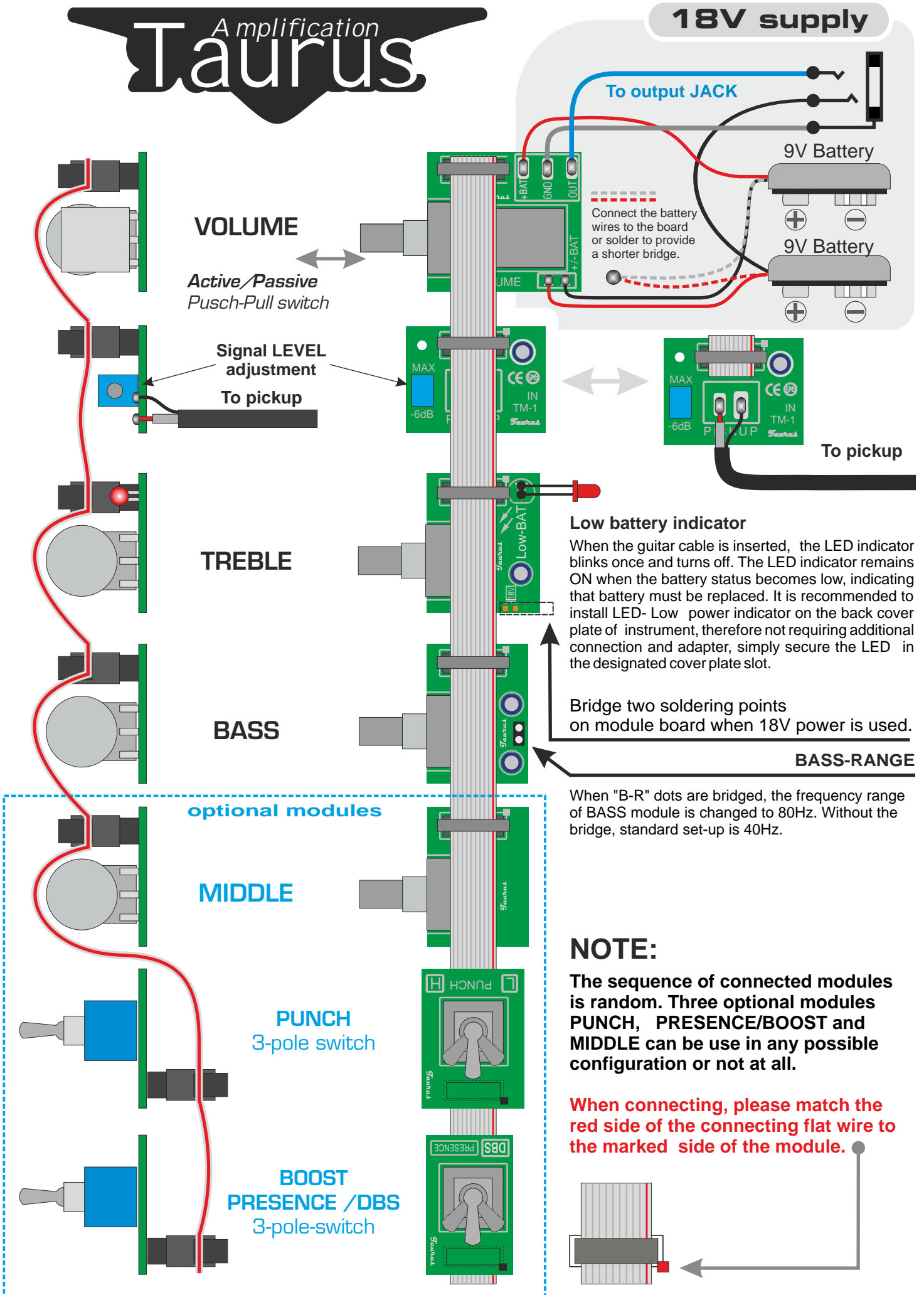

DIMENSIONS

